

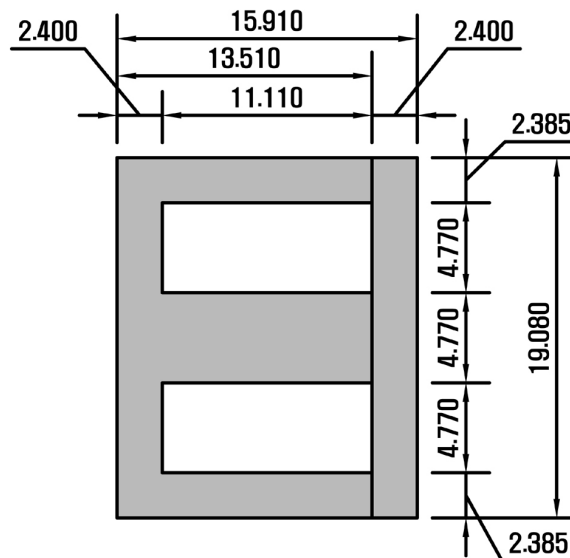

LAMINATION TYPE 187EI



TOLERANCE $\pm 0.08\text{mm}$

PROPERTIES OF SQUARE STACK

MAGNETIC DESIGN FORMULAE

$$B_{\text{max}} = 1652 \times 10^3 / K_1 N (\text{gauss per Volt at 60 Cycle})$$

(N is number of turns)

$$H_o = (0.304 \times 10^{-3}) N \text{ Oersted per milliampere}$$

of direct current in windin

$$L = (0.0690 \times 10^{-8}) K_1 N^2 \mu \text{ ac Henries}$$

MAGNETIC PATH Dimension

$$l = 4.13\text{cm}$$

$$A = 0.227\text{cm}^2$$

K₁ (STACKING FACTOR)

	Thickness	Butt jointed	Interleaved one per layer
	0.1	.90	.80
	0.2	.90	.85
	0.35	.95	.90

MATERIAL TYPE	THICKNESS(mm)	WEIGHT AND COUNT	
		g/pair	pairs/kg
PC(Ni80)	0.35t	0.605	1,652
PC(Ni80)	0.35t	0.570	1,754